

ANALOG INPUT MODULE – AIM08



Features

- ▶ Analog input module for 2 electrically isolated signals – 3-wire connections
- ▶ Analog input module for 8 single ended signals, 2- or 3-wire connections
- ▶ Electrical isolation between the inputs and the system bus
- ▶ Signal preprocessing possible – e.g. parametrisable averaging
- ▶ Selectable 0 .. 10 V or 0 .. 20 mA inputs; signal can be selected by jumper for each input
- ▶ 10 bit resolution / multiplex mode
- ▶ Range 0 .. 20 mA, 4 ..20 mA parametrisable by software
- ▶ Cross-communication to other modules
- ▶ Communication by CANopen DS-401, autobaud-recognition
- ▶ Anti-aliasing-filter integrated
- ▶ Module address type-specifically adressable by a front-switch
- ▶ LED for life check
- ▶ Ultra compact design

Connection diagram and terminal assignment AIM08

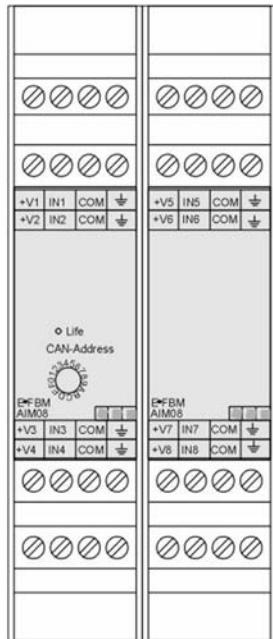

V1, 2, 5, 6 Sensor supply 10 VDC
 V3, 4, 7, 8 Sensor supply 24 VDC
 COM Signal grounded für V1 .. 8
 IN1 .. 8 Input 1 .. 8

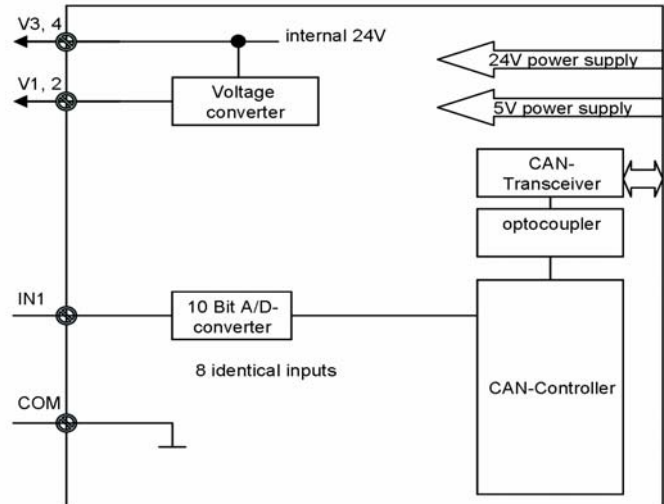

Technical specifications

Electrical connection

- ▶ Supply voltage: 5 VDC and 24 VDC by internal ME-bus
- ▶ Supply:
 - Control voltage for sensor supply: typ. 24 VDC (18 .. 32 VDC) via ME bus
 - Logic voltage: typ. 5.0 VDC (4.75 .. 5.25 VDC) via ME bus
- ▶ Supply current: max. 90 mA via 24 V system bus, max. 260 mA via 5 V system bus

Interfaces

- ▶ Number of inputs: 8 channels
- ▶ Input voltage range: 0 .. 10 V; max. 15 V; resolution 10 Bit, 1 MOhm
- ▶ Sensor supply: 0 .. 20 mA, resolution 10 bit, shunt maximum 499 Ohm
- ▶ Max. signal frequency: 1000 Hz
- ▶ Parameterisable filter: Parametrisable digital filter for averaging
- ▶ Isolation voltage: 500 V
- ▶ Monitoring functions: Watchdog; thermal and short-circuit protection

Housing

- ▶ Module width: 45 mm
- ▶ Address range: By switch in the range of 60 .. 6F hex
- ▶ Temperature range: -20°C bis +70°C; transport and storage
+0°C bis +50°C; operation
- ▶ Relative humidity: 5 – 95 %, non-condensing
- ▶ Protection: IP20
- ▶ Standards: EC conformation declaration according
 - ▶ 89/336/EWG (EMC-standards)
 - ▶ 73/23/EWG (low voltage standard)